

WEITAI

WEITAI WSL SERIES

SKID STEER LOADER ATTACHMENTS

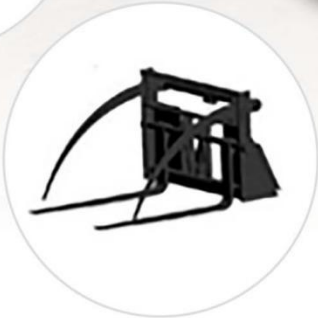

青岛威泰智能装备有限公司

QINGDAO WEITAI INTELLIGENT EQUIPMENT CO., LTD.

目录

1. 通用附具 UNIVERSAL ATTACHMENTS	5
1.1 栅格铲斗 SKELETON BUCKETS	5
1.2 货叉 PALLET FORKS	5
1.3 标准铲斗 STANDARD BUCKETS	5
1.4 四合一铲斗 4-IN-1 BUCKETS	6
1.5 翻转式铲斗 ROLLOUT BUCKET	6
2. 市政附具 CITY INFRASTRUCTURE ATTACHMENTS	8
2.1 井盖铣刨机 MANHOLE COVER MILLING MACHINE	8
2.2 斜角清扫器 ANGLE BROOMS	8
2.3 封闭清扫器/专用封闭清扫器 ENCLOSED SWEEPERS/SPECIALIZED ENCLOSED SWEEPERS	9
2.3.1 普通路面清扫器 STANDARD ROAD SWEEPERS	9
2.3.2 铣刨路面专用清扫器 SPECIALIZED MILLED PAVEMENT SWEEPERS	9
2.4 破碎锤 HYDRAULIC HAMMERS	9
2.5 PD 轮振动压实器 PD WHEELED VIBRATORY ROLLERS	10
2.6 振动压实器 VIBRATORY ROLLERS	10
2.7 开沟机 TRENCHERS	11
2.8 铣刨器 PLANERS	11
2.9 推雪铲 SNOW BLADES	12
2.10 推土板 DOZER BLADES	12
2.11 抛雪机 SNOW BLOWERS	13
2.12 LA-029 型破冰机 LA-029 SERIES ICE BREAKER	13
2.13 除冰器 DEICERS/ICE SCRAPERS	13
2.14 箱式推雪器 BOX TYPE SNOW PUSHERS	14
2.15 铲雪斗 SNOW BUCKETS	14
2.16 V 型推雪板 V-SHAPED SNOW BLADES	14
3. 建筑附具 CONSTRUCTION ATTACHMENTS	16
3.1 LA-031 系列挖掘器 LA-031 SERIES BACKHOES	16
3.2 LA-032 系列挖掘器 LA-032 SERIES BACKHOES	16
3.3 落锤 DROP HAMMER	17
3.4 水泥布料机 CONCRETE SPREADERS	18
3.5 搅拌器 CONCRETE MIXER	18
3.6 板材搬运器 BOARD CARRIER	19
3.7 盘式开沟机 WHEEL TRENCHERS	19
3.8 盘踞 WHEEL SAWS	20
3.9 挖掘臂 DIGGER ARMS	20
4. 工业物流附具 INDUSTRIAL LOGISTIC ATTACHMENTS	22
4.1 抱叉 PALLET FORKS	22
4.2 串杆 BALE SPEAR	22
4.3 LA-043 系列物料抓斗 LA-043 SERIES GRAPPLE FORKS	22
4.4 LA-044 系列抓斗 LA-044 SERIES GRAPPLE FORKS	23
4.5 带侧移货叉 SIDE SHIFT PALLET FORKS	23
4.6 油桶夹 BARREL CLAMPS	23
4.7 U 型集料斗 U-SHAPED BUCKET	24
4.8 吊钩 CRANE JIBS	24
4.9 圆木抱叉 LOGGING GRABS	24

5. 园林/农附具 FORESTRY/AGRICULTURAL ATTACHMENTS	26
5.1 农用抓斗 AGRICULTURAL GRAPPLE FORKS	26
5.2 三瓣式 移树机 THREE PETAL TYPE SPADES	26
5.3 四瓣式(植)移树机 FOUR PETAL TYPE TREE SPADES	26
5.4 软包夹 SOFT CLAMPS	27
5.5 铲运器 SCRAPERS	27
5.6 平地器 GRADERS	28
5.7 抓耙器 GRAPPLE RAKES	28
5.8 草捆叉 BALE SPEARS	28
5.9 割草机 LAWN MOVERS	29
5.10 抓草机 GRASS RAKES	29
5.11 旋耕机 ROTARY TILLERS	29
5.12 树剪 TREE SHEARS	30
5.13 拓荒机 FRONTIER ATTACHMENT	30
5.14 可调式地面清理器 ADJUSTABLE GROUND CLEANERS	31
5.15 卧床旋转式疏松器 CATTLE BEDDING ROTARY LOOSENER	31
5.16 卧床清扫刷 CATTLE BEDDING SWEEPER	32
5.17 清扫刷 SWEEPERS	32
6. 其他附具 OTHER ATTACHMENTS	34
6.1 回料机 FEEDERS	34
6.2 抛料机 THROWER	34
6.3 回料螺旋旋转 FEEDER SPIRAL ROTATORS	35
6.4 抱草夹 GRASS CLAMPS	35
7. 螺旋钻 AUGERS	36
7.1 两种形式安架选型 2 TYPES OF MOUNTING OPTIONS	36
7.2 螺旋钻机 AUGERS	36
7.3 LA-S4 螺旋钻杆系列 LA-S4 SERIES AUGER RODS	37
7.4 LA-S5 系列延伸杆选型 LA-S5 SERIES EXTENSION ROD SELECTION	39
8. 连续开沟器 CONTINUOUS DITCHERS	40
8.1 LA-073 系列 LA-073 SERIES	40
8.2 LA-074 系列 LA-074 SERIES	42
9. 连滑移装载机配液压工具栏 SKID STEER LOADERS HYDRAULIC TOOLBARS	43
9.1 动力站-滑移装载机 SKID STEER LOADER POWER STATION	43
9.2 液压圆盘锯 - LA-25 HYDRAULIC CIRCULAR SAW-LA-25	44
9.3 液压金刚石链锯 - LA-11 HYDRAULIC DIAMOND CHAINSAW- LA-11	44
9.4 液压链锯- LA-06 HYDRAULIC CHAINSAW- LA-06	45
9.5 液压手持镐 - LA-15 HYDRAULIC HAND PICK- LA-15	45
9.6 液压轻型破碎镐 - LA-45 HYDRAULIC LIGHT BREAKING PICK- LA-45	46
9.7 破碎镐 - LA-67 BROKEN PICKAXE-LA-67	46
9.8 液压锤钻 - LA-08 HYDRAULIC HAMMER DRILL - LA-08	47
9.9 液压锤钻 - LA-45 HYDRAULIC HAMMER DRILL - LA-45	47
9.10 液液潜孔钻 - LA-58 HYDRAULIC DTH DRILL - LA-58	48
9.11 液压岩心钻 - LA-12 HYDRAULIC CORE DRILL - LA-12	48
9.12 液压污水泵 - LA-20 HYDRAULIC SEWAGE PUMP - LA-20	49
9.13 液压渣浆泵 - LA-03 HYDRAULIC SLURRY PUMP - LA-03	49
9.14 液压渣浆泵 - LA-08 HYDRAULIC SLURRY PUMP - LA-08	50



通用附具

UNIVERSAL ATTACHMENTS



1. 通用附具 UNIVERSAL ATTACHMENTS

1.1 栅格铲斗 SKELETON BUCKETS

	型号 Model	总长 Overall Length (mm)	总宽 Overall Width (mm)	总高 Overall Height (mm)	斗容 Bucket Capacity (m³)	最大流量 Max. flow (l/min)	最大压力 Max. Pressure (MPa)	最大频率 Max. Frequency (Hz)	最大激振力 Max. Excitation Force (kN)
	LA-011-1500	812	1524	508	0.34	70	20	12	1.5
	LA-011-1700	812	1676	508	0.39	70	20	12	1.5
	LA-011-1800	812	1828	508	0.42	70	20	12	1.5
	LA-011-2000	812	1982	508	0.45	70	20	12	1.5
	LA-011-2100	812	2134	508	0.5	70	20	12	1.5

1.2 货叉 PALLET FORKS

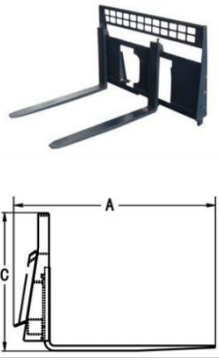
	型号 Model	总长 Overall Length A (mm)	总宽 Overall Width B (mm)	总高 Overall Height C (mm)	总重 Overall Weight (kg)	货叉最大调整 间距 Fork Max. Adjustment Distance (mm)	货叉最小调整 间距 Fork Min. Adjustment Distance (mm)	货叉安装距 Fork Installation Distance (mm)
	LA-012-1200	1298	1206	890	162	1143	230	380
	LA-012-1600	1298	1587	890	207	1524	230	380

1.3 标准铲斗 STANDARD BUCKETS

	型号 Model	总长 Overall Length (mm)	总宽 Overall Width (mm)	总高 Overall Height (mm)	斗容 Bucket Capacity (m³)
	LA-013-1500	812	1524	508	0.34
	LA-013-1700	812	1676	508	0.39
	LA-013-1800	812	1828	508	0.42
	LA-013-2000	812	1982	508	0.45
	LA-013-2100	812	2134	508	0.5

1.4 四合一铲斗 4-IN-1 BUCKETS

	型号 Model	总宽 Overall Width A (mm)	总高 Overall Height B (mm)	总长 Overall Length C (mm)	张开距 Opening Distance (mm)	系统压力 System Pressure (MPa)	夹紧力 Clamp Force (N)	总重(约) Overall Weight (approximate) (kg)	斗容量(约) Bucket Capacity (approximate) (m ³)
	LA-014-1600	1584	768	879	718	20	8230	385	0.4
	LA-014-1700	1736	768	879	718	20	8230	420	0.44
	LA-014-1900	1889	768	879	718	20	8230	460	0.48

1.5 翻转式铲斗 ROLLOUT BUCKET

	型号 Model	工作宽度 Working Width (mm)	斗刃宽度 Blade Width (mm)	最大宽度 Max. Width (mm)	最大高度 Max. Height (mm)	最大长度 Max. Length (mm)	最大翻转 角 Max. Flip Angle	斗容量 Bucket Capacity (m ³)
	LA-015-1800	1830	1980	2030	640	1046	80°	0.6

WEITAI

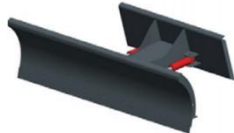
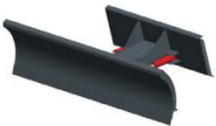

市政附具
CITY
INFRASTRUCTURE
ATTACHMENTS

2. 市政附具 CITY INFRASTRUCTURE ATTACHMENTS

2.1 井盖铣刨机 MANHOLE COVER MILLING MACHINE

	型号 Model	井盖铣刨机 总直径 A Manhole Cover Milling Machine Overall Diameter A (mm)	总高 B Over all Heig ht B (mm)	铣刨直径 Milling Diameter (mm)	铣刨直径可 调范围 Adjustable Range of Milling Diameter (mm)	最大铣 刨深度 Max. Milling Depth (mm)	定位器适用井 口直径 Suitable Locator for the Diameter of the Wellhead (mm)	压力范 围 Pressu re Range (MPa)	操作 重量 Operat ing Wei ght (kg)
	LA-215-1400	1380	2300	1360	1100-1400	300	550-750	18-26	550

2.2 斜角清扫器 ANGLE BROOMS

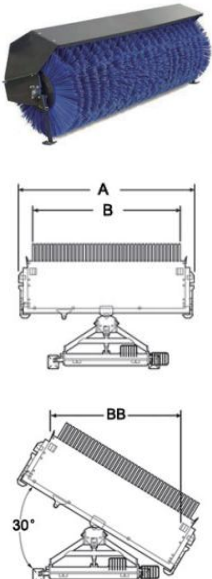
	型号 Model	净重 Net Weight (kg)	工作宽度 B Working Width B (mm)	总宽 A Overall Width A (mm)	毛刷直径 Brush Diameter (mm)	转角 (30°) 后 工作宽度 BB Working Width BB (above 30° angle) (mm)	马达流 量 Motor Flow Range (gpm)	工作压力 Working Pressure (psi)
	LA-021-1500	375	1524	1790	812	1371	10-25	2000-3500
	LA-021-1800	441	1828	2095	812	1625	10-25	2000-3500
	LA-021-2100	498	2133	2400	812	1965	10-25	2000-3500

2.3 封闭清扫器/专用封闭清扫器 ENCLOSED SWEEPERS/SPECIALIZED

ENCLOSED SWEEPERS

2.3.1 普通路面清扫器 STANDARD ROAD SWEEPERS

	型号 Model	净重 Net Weight (kg)	工作宽度 Working Width (mm)	总长 A Overall Length A (mm)	总宽 B Overall Width B (mm)	总高 C Overall Height C (mm)	毛刷直径 Broom Diameter (mm)	储仓容量 Bucket Capacity (m³)	马达流量 Motor Flow Range (gpm)	工作压力 Working Pressure (psi)
	LA-022-1500	433	1524	1394	1676	663	660	0.39	14-25	2000-3500
	LA-022-1800	492	1828	1394	1981	663	660	0.48	14-25	2000-3500
	LA-022-2100	535	2133	1394	2286	663	660	0.56	14-25	2000-3500

2.3.2 铣刨路面专用清扫器 SPECIALIZED MILLED PAVEMENT SWEEPERS

	型号 Model	净重 Net Weight (kg)	工作宽度 Working Width (mm)	总长 A Overall Length A (mm)	总宽 B Overall Width B (mm)	总高 C Overall Height C (mm)	毛刷直径 Broom Diameter (mm)	储仓容量 Bucket Capacity (m³)	马达流量 Motor Flow Range (gpm)	工作压力 Working Pressure (psi)
	LA-022Z-1500	455	1524	1394	1676	663	660	0.39	14-25	2000-3500
	LA-022Z-1800	536	1828	1394	1981	663	660	0.48	14-25	2000-3500
	LA-022Z-2100	573	2133	1394	2286	663	660	0.56	14-25	2000-3500

2.4 破碎锤 HYDRAULIC HAMMERS

	型号 Model	操作重量 Operating Weight (kg)	总长 Overall Length (mm)	工作油压 Working Oil Pressure (bar)	流量 Flow Range (l/min)	打击频率 Strike Frequency (blows per minute)	钎杆直径 Drill Rod Diameter (mm)	冲击功 Impact Energy (J)
	LA-023-1200	260	1160	80-100	20-35	650-1200	45	225
	LA-023-1300	310	1300	90-120	25-40	550-1100	57	400
	LA-023-1450	327	1450	90-120	24-50	550-1100	53	325
	LA-023-1500	360	1520	95-130	34-60	450-1000	60	600
	LA-0230-1650	370	1680	100-140	40-80	475-950	68	700
	LA-023-1750	380	1750	130-150	45-85	480-850	75	1200

2.5 PD 轮振动压实器 PD WHEELED VIBRATORY ROLLERS

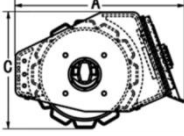
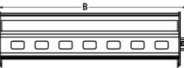
  	型号 Model	总宽 B Overall Width B (mm)	钢轮宽 Drum Width (mm)	总高 C Overall Height C (mm)	总长 A Overall Length A (mm)	钢轮直径 Drum Diameter (mm)	操作重量 Operating Weight (kg)	振动力 Vibration Force (kN)	振动速度 Vibration Speed (vpm)	钢轮倾斜角度 Drum Inclination Angle
	LA-024-1100	1067	914	565	864	530	523	20	2600	15°
LA-024-1600	1550	1220	565	864	530	740	26	2600	15	
LA-024-1700	1720	1614	565	864	530	890	31	2600	15	
LA-024-1800	1830	1677	788	990	609	980	35	2600	15	
LA-024-2000	2007	1855	788	990	609	1044	39	2600	15	
LA-024-2300	2286	2134	788	990	609	1149	43	2600	15	

2.6 振动压实器 VIBRATORY ROLLERS

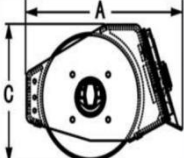
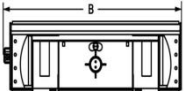
  	型号 Model	总宽 B Overall Width B (mm)	钢轮宽 Drum Width (mm)	总高 C Overall Height C (mm)	总长 A Overall Length A (mm)	钢轮直径 Drum Diameter (mm)	操作重量 Operating Weight (kg)	振动力 Vibration Force (kN)	振动速度 Vibration Speed (vpm)	钢轮倾斜角度 Drum Inclination Angle
	LA-025-1100	1901	914	565	864	530	581	20	2600	15°
LA-025-1600	1550	1220	565	864	530	763	26	2600	15	
LA-025-1700	1720	1614	565	864	530	872	31	2600	15	
LA-025-1800	1830	1677	788	990	609	976	35	2600	15	
LA-025-2000	2007	1855	788	990	609	1104	39	2600	15	
LA-025-2300	2286	2134	788	990	609	1231	43	2600	15	

2.7 开沟机 TRENCHERS

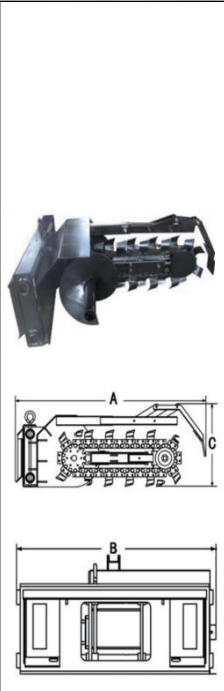
	型号 Model	α65°开掘深度 α65° Excavation Depth (mm)	总宽 B Overall Width B (mm)	开掘宽度 Digging Width (mm)	开掘角度 Digging Angle	总长 A Overall Length A (mm)	总高 C Overall Height C (mm)	卸料距离 Dumping Distance (mm)	流量范围 Flow Range (l/min)	压力范围 Pressure Range (MPa)	操作重量 Operating Weight (kg)
	LA-027-600	600	1065	150-300	65°	1295	710	600	40-100	14-22	459
	LA-027-800	760	1065	150-300	65	1295	710	600	25-50	14-22	502
	LA-027-900	915	1065	150-300	65	1295	710	600	25-50	14-22	545
	LA-027-1200	1220	1065	150-300	65°	1295	710	600	25-50	14-22	590

2.8 铣刨器 PLANERS

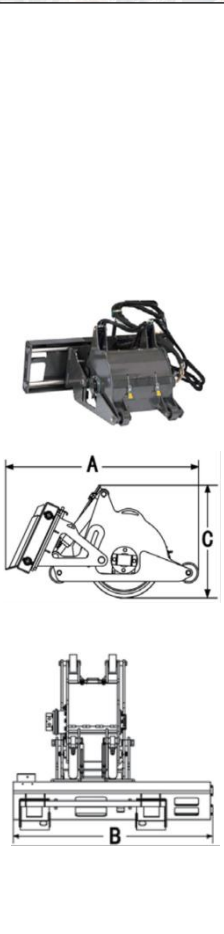
	型号 Model	操作重量 Operating Weight (kg)	总长 A Overall Length A (mm)	总宽 B Overall Width B (mm)	总高 C Overall Height C (mm)	铣刨宽度 Planer Width (mm)	最大铣刨深度 Max. Milling Depth (mm)	流量范围 Flow Range (l/min)	铣刨刀具数量 Number of Planer Cutters	最大铣刨角度 Max. Milling Angle	路面铣刨器侧移距离 Sideshift Distance of the Planer (mm)	系统压力 System Pressure (MPa)	附具需要流量 Attachment Required Flow
	LA-026-300	614	1526	1674	852	300	110	60-150	32	± 15°	660	20	标准 Standard
	LA-026-350	663	1526	1674	852	350	110	100-180	40	±15	660	20	标准 Standard
	LA-026-400	760	1526	1674	852	400	152	100-180	48	± 15°	660	20	大流量 Big Flow
	LA-026-500	865	1526	1674	852	500	152	100-180	56	± 15°	660	20	大流量 Big Flow
	LA-026-600	964	1526	1674	852	600	152	120-200	64	± 15°	660	20	大流量 Big Flow

2.9 推雪铲 SNOW BLADES

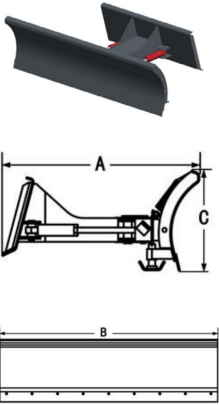
	型号 Model	总长 A Overall Length A (mm)	总宽 B Overall Width B (mm)	总高 C Overall Height C (mm)	工作宽度 Working Width (mm)		最大 转角 Max. Steerin g Angle
						转 30°角后 After Turning 30°	
	LA-028-1500	1207	1520	580	1520	1316	30°
	LA-028-1800	1207	1830	580	1830	1585	30°
	LA-028-2100	1207	2130	580	2130	1845	30°
	LA-028-2400	1207	2440	580	2440	2113	30°

2.10 推土板 DOZER BLADES

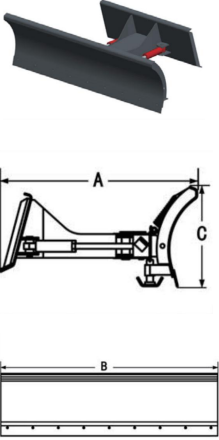
	型号 Model	总长 A Overall Length A (mm)	总宽 B Overall Width B (mm)	总高 C Overall Height C (mm)	工作宽度 Working Width (mm)		最大 转角 Max. Steerin g Angle
						转 30°角后 After Turning 30°	
	LA-028-1500	1207	1520	750	1520	1316	30°
	LA-028-1800	1207	1830	750	1830	1585	30°
	LA-028-2100	1207	2130	750	2130	1845	30°
	LA-028-2400	1207	2440	750	2440	2113	30°

2.11 抛雪机 SNOW BLOWERS

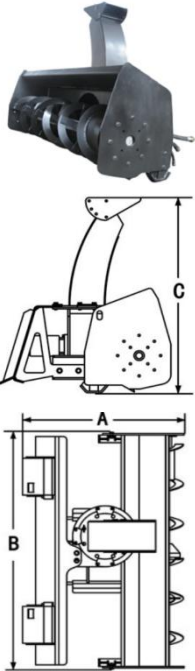
	型号 Model	工作宽度 Working Width (mm)	总长 A Overall Length A (mm)	总宽 B Overall Width B (mm)	总高 C Overall Height C (mm)	工作高度 Working Height (mm)	重量 Weight (kg)
	LA-029-1300	1220	866	1250	1204	580	396
	LA-029-1600	1520	866	1550	1204	580	454
	LA-029-1900	1830	866	1860	1204	580	538
	LA-029-2000	1981	866	2011	1204	580	607
	LA-029-2200	2130	866	2160	1204	580	695

2.12 LA-029 型破冰机 LA-029 SERIES ICE BREAKER

	型号 Model	总宽 Overall Width (mm)	圆筒宽 Cylinder Width (mm)	总高 Overall Height (mm)	总长 Overall Length (mm)	圆筒直径 Cylinder Diameter (mm)	重量 Weight (kg)	破冰最大厚 度 Max. Ice Breaking Thickness (mm)
	LA-029-1800	1830	1540	900	1380	600	1435	150

2.13 除冰器 DEICERS/ICE SCRAPERS

	型号 Model	总长 A Overall Length A (mm)	总高 B Overall Height B (mm)	总宽 C Overall Width C (mm)	刀盘直径 D Cutter Diameter D (mm)	总重 Overall Weight (kg)	破冰高度 Ice Breaking Height (mm)
	LA-210-1100	1270	488	1143	457	70	10-100
	LA-210-1150	1273	565	1150	560	84.5	10-100

2.14 箱式推雪器 BOX TYPE SNOW PUSHERS

	型号 Model	总长 A Overall Length A (mm)	总宽 B Overall Width B (mm)	工作宽度 Working Width (mm)	总高 C Overall Height C (mm)	深度 Depth (mm)	重量 Weight (kg)
	LA-212-1700	1290	1672	1520	1143	1032	481
	LA-212-2000	1290	1982	1830	1143	1032	551
	LA-212-2300	1290	2282	2130	1143	1032	622
	LA-212-2600	1290	2592	2440	1143	1032	692

2.15 铲雪斗 SNOW BUCKETS

	型号 Model	总长 A Overall Length A (mm)	总宽 B Overall Width B (mm)	总高 C Overall Height C (mm)	容积 (m ²) Area	堆积容积 Bulk Volume (m ³)	重量 Weight (kg)
	LA-211-1500	950	1544	777	0.64	0.7	322
	LA-211-1900	950	1854	777	0.76	0.9	368
	LA-211-2200	950	2154	777	0.88	1.10	428
	LA-211-2500	950	2464	777	1.00	1.30	458

2.16 V 型推雪板 V-SHAPED SNOW BLADES

	型号 Model	高度 Height (mm)	长度 Length (mm)	工作宽度 V 型 Working Width V-Type (mm)	收集工作宽度 U 型 Collecting Working Width U-Type (mm)	工作宽度直型 Working Width Straight-Type (mm)	工作宽度向左或向右 30°角 Working Width at 30° Left/Right (mm)	重量 Weight (kg)
	LA-213-1400	724	1016	1372	1346	1575	1372	299
	LA-213-1600	833	1201	1638	1600	1880	1626	335
	LA-213-1900	833	1201	1905	1880	2184	1905	353
	LA-213-2200	833	1201	2172	2134	2489	2159	374



建筑附具

CONSTRUCTION ATTACHMENTS



3. 建筑附具 CONSTRUCTION ATTACHMENTS

3.1 LA-031 系列挖掘器 LA-031 SERIES BACKHOES

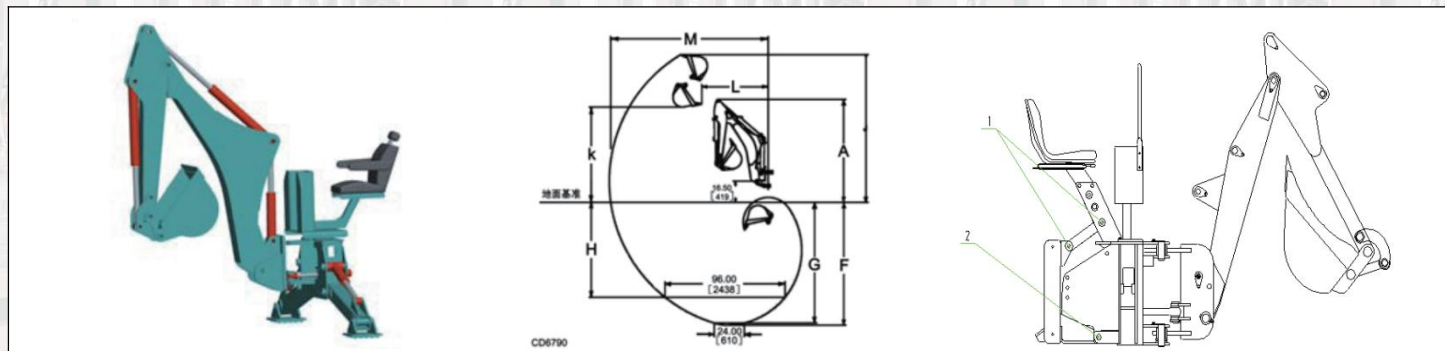

挖掘器型号 Backhoe Model	LA-031-003	LA-031-0048	LA-031-006
配套动力 Supporting Power (hp)	25-35	35-55	60-80
机具外形尺寸 (长 x 宽 x 高) Machine Dimensions (LxWxH) (mm)	2601x2000x2460	2601x2000x2460	2601x2000x2460
额定斗容量 Rated Bucket Capacity (m ³)	0.03	0.048	0.06
最大挖掘深度 Max. Excavation Depth (mm)	1700	2300	2400
最大平底挖掘深度 Max. Flat Bottom Digging Depth (mm)	1600	2000	2500
最大挖掘高度 Max. Excavation Height (mm)	2700	3300	3400
卸载高度 Dumping Height (mm)	1700	2300	2500
动臂销轴离地高度 Boom Pin Height from the Ground (mm)	430	430	450
卸料角 Discharge Angle	42°	42°	42°
系统压力 System Pressure (MPa)	16	16	16
料斗转角 Hopper Angle	180°	180°	180°
动臂回转角度 Boom Rotation Angle	147°	147°	147°

3.2 LA-032 系列挖掘器 LA-032 SERIES BACKHOES

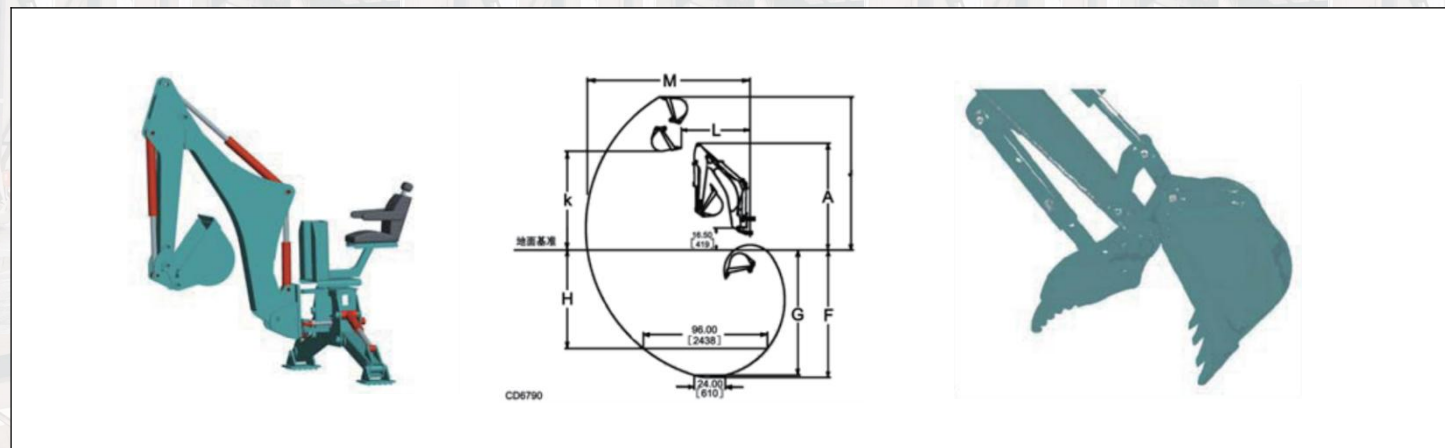

项目 Model	图示尺寸 Size	LA-032-004L	LA-032-004H
运输尺寸 Transportation Size	A (mm)	1899	2090
支腿最小宽度 Leg Min. Width	(mm)	1486	1486
支腿作业宽度 Leg Working Width	(mm)	2248	2248
最大挖掘深度 Max. Digging Depth	F (mm)	2191	2489
最大作业高度 Max. Working Height	(mm)	2750	2978
装载高度 Max. Loading Height	K (mm)	1676	1161
装载近距 Loading Low Coverage	L (mm)	1149	1334
作业半径 Working Radius	M (mm)	2883	3188
挖斗旋转角 Bucket Rotation Angle	(°)	180	180
大臂回转角 Arm Rotation Angle	(°)	120	120
标配斗容 Standard Bucket Capacity	(m ³)	0.04	0.04
重量 Weight	(kg)	560	610
系统压力 System Pressure	(MPa)	14-21	14-21
系统流量 System Flow Range	(lpm)	15-23	19-26

3.3 落锤 DROP HAMMER

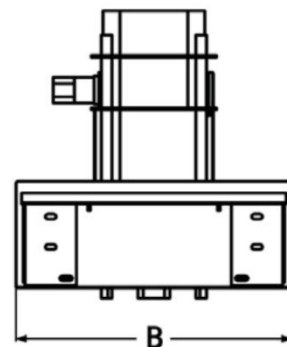
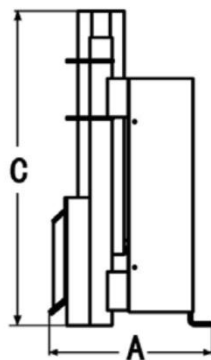

总宽 B Overall Width B (mm)	1300
总长 A Overall Length A (mm)	705
总高 C Overall Height C (mm)	2196
锤重 Hammer Weight (kg)	200
锤长 Hammer Length (mm)	1420
总重 Overall Weight (kg)	694

3.4 水泥布料机 CONCRETE SPREADERS

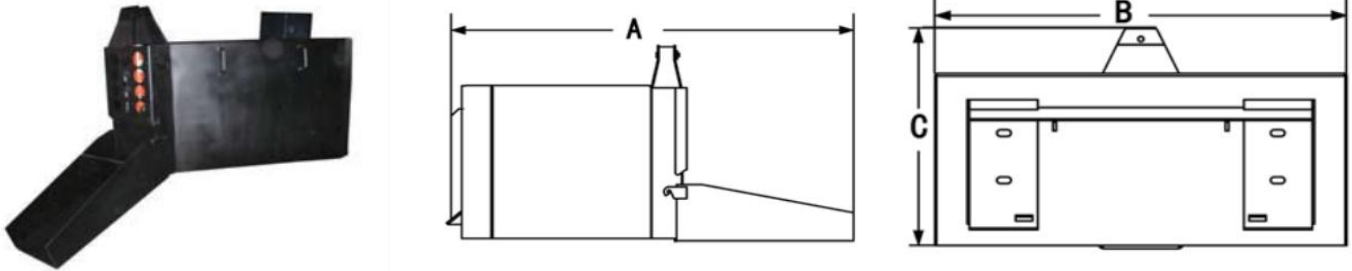
		
型号 Model	LA-033-1450	LA-033-1500
自重 Dead Weight (kg)	213	276
总长 A Length A (mm)	950	978
总宽 B Width B (mm)	1460	1524
总高 C Height C (mm)	832	896
举升重量 Lift Weight (kg)	545	772

3.5 搅拌器 CONCRETE MIXER

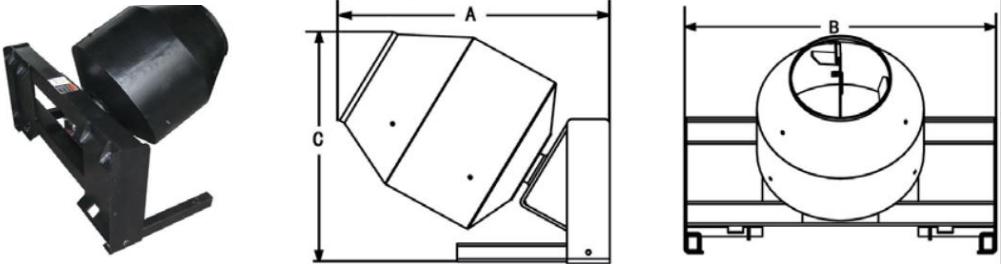
		
总长 A Length A (mm)		1270
总宽 B Width B (mm)		1295
总高 C Height C (mm)		1067
滚筒大小 Roller Size (m ³)		0.27
一罐生产量 Production Capacity of One Tank (m ³)		0.3
搅拌速度 (可变) Mixing Speed (Variable) (rpm)		5~30
液压流量 Hydraulic Flow Range (l/min)		0~112.5
最大工作压力 Max. Working Pressure (MPa)		21
重量 Weight (kg)		236

3.6 板材搬运器 BOARD CARRIER

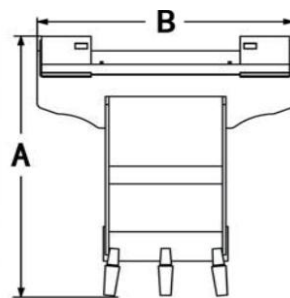
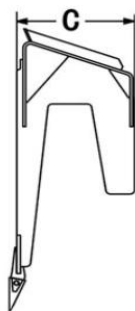

型号 Model	自重 Dead Weight (kg)	工作宽度 Working Width (mm)	总长 A Overall Length A (mm)	总宽 B Overall Width B (mm)	总高 C Overall Height C (mm)	搬运厚度 Carrying Thickness (mm)	举升重量 Lift Weight (kg)	搬运重量 Carrying Weight (kg)
LA-036-1300	337	610	1460	1260	558	190	<4540	<14528

3.7 盘式开沟机 WHEEL TRENCHERS



型号 Model	LA-035-2000	LA-035-2050
总宽 Overall Width (mm)	1700	1700
总高 Overall Height (mm)	2006	2057
总长 Overall Length (mm)	1930	2184
最大切削深度 Max. Digging Depth (mm)	125-457	230-610
刀盘直径 Cutterhead Diameter (mm)	1219	1524
刀头个数 Cutterhead Quantity	42	56
流量范围 Flow Range (l/min)	117-125	130-150
压力 Pressure (MPa)	15-21	15-21
操作重量 1Bs Operating Weight 1Bs	刀盘宽度 Cutter head Width	80
	刀盘宽度 Cutter head Width	180
		210
		245

3.8 盘踞 WHEEL SAWS



型号 Model	LA-037-300	LA-037-500	LA-037-600	LA-037-700	LA-037-900
刀片型式 Bit Type	钻石型 Diamond	钻石型 Diamond	钻石型 Diamond	钻石型 Diamond	钻石型 Diamond
最大直径 Max. Diameter (mm)	300	500	600	700	900
最大切割深度 Max. Cutting Depth (mm)	120	180	260	310	380
系统流量 System Flow (l/min)	40-60	50-80	06-09	70-100	70-100
系统压力 System Pressure (MPa)	14-21	14-21	14-21	14-21	14-2
重量 Weight (kg)	369	375	382	391	402

3.9 挖掘臂 DIGGER ARMS

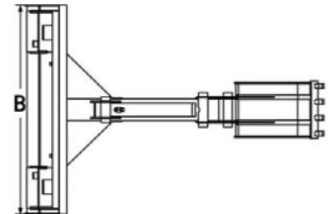
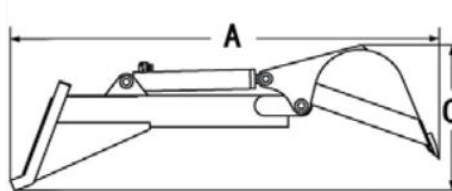

型号 Model	LA-038-12	LA-038-18	LA-038-24
总长 A Overall Length A (mm)	1869	1869	1869
总宽 B Overall Width B (mm)	1320	1320	1320
总高 C Overall Height C (mm)	776	776	776
总重 Overall Weight (kg)	386	425	461
挖斗宽度 Bucket Width (mm)	330	485	635
挖斗型号 Bucket Type (inch)	12"	18"	24"
标准斗容 Standard Bucket Capacity (m ³)	0.04	0.06	0.08
挖掘深度 Digging Depth (mm)	1675	1675	1675

WEITAI

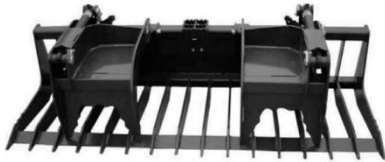

工业物流附具
INDUSTRIAL
LOGISTIC
ATTACHMENTS

4. 工业物流附具

INDUSTRIAL LOGISTIC ATTACHMENTS

4.1 抱叉 PALLET FORKS

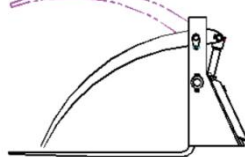
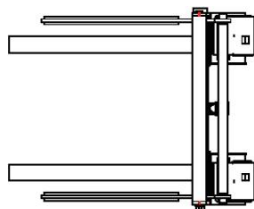

型号 Model	LA-041-1200	LA-041-1600
总长 Overall Length (mm)	1552	1552
总宽 Overall Width (mm)	1206	1587
总高 Overall Height (mm)	890	890
最大宽度 Max. Width (mm)	1143	1524

4.2 串杆 BALE SPEAR



型号 Model	LA-042-1500
总长 Overall Length (mm)	1927
总宽 Overall Width (mm)	1524
总高 Overall Height (mm)	500
串杆直径 Spear Diameter (mm)	70
串杆长度 Spear Length (mm)	1625

4.3 LA-043 系列物料抓斗 LA-043 SERIES GRAPPLE FORKS



型号 Model	LA-043-1550	LA-043-1700	LA-043-1850
总长 Overall Length (mm)	915	915	915
总宽 Overall Width (mm)	1543	1695	1848
总张开高度 Overall Height at the Open Position (mm)	864	864	864
总闭合高度 Overall Height at the Shut Position (mm)	502	502	502

4.4 LA-044 系列抓斗 LA-044 SERIES GRAPPLE FORKS



型号 Model	LA-044-1500	LA-044-1700	LA-044-1850
总长 Overall Length (mm)	915	915	915
总宽 Overall Width (mm)	1543	1695	1848
总张开高度 Overall Height at the Open Position (mm)	864	864	864
总闭合高度 Overall Height at the Shut Position (mm)	502	502	502

4.5 带侧移货叉 SIDE SHIFT PALLET FORKS



型号 Model	LA-047-1200	LA-047-1600
总长 Overall Length (mm)	1598	1598
总宽 Overall Width (mm)	1206	1587
总高 Overall Height (mm)	890	890
总重 Overall Weight (kg)	262	307
货叉最大调整间距 Fork Max. Adjustment Distance (mm)	1143	1524
货叉最小调整间距 Fork Min. Adjustment Distance (mm)	230	230
货叉安装距 Fork Installation Distance (mm)	380	380
左右旋转角度 Left/Right Rotation Angle	30°	30°

4.6 油桶夹 BARREL CLAMPS

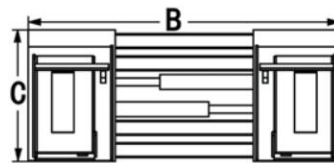
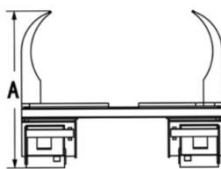

型号 Model	LA-049-700	LA-049-1300
总长 A Overall Length A (mm)	991	991
总宽 B Overall Width B (mm)	1271	1271
总高 C Overall Height C (mm)	582	582
桶数 Barrel Quantity	1~2	1~2
载荷量 Load (kg)	700	1250
张臂范围 Arm Spread Range (mm)	420~1600	440~1620
自重 Dead Weight (kg)	332	378

4.7 U 型集料斗 U-SHAPED BUCKET

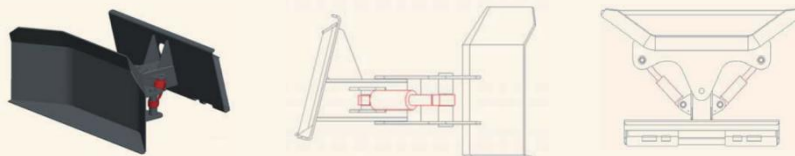

型号 Model	LA-048-1500	LA-048-1800	LA-048-2100
总长 Overall Length (mm)	1520	1830	2130
总宽 Overall Width (mm)	990	990	990
总高 Overall Height (mm)	577	577	577
偏转角度 Deflection Angle	30°	30°	30°
料斗容积 Hopper Capacity (m ³)	0.67	0.76	0.85
流量范围 Range of Flow (l/min)	20-60	20-60	20-60
压力范围 Pressure Range (MPa)	12-21	12-21	12-21
操作重量 Operating Weight (kg)	334	397	451

4.8 吊钩 CRANE JIBS

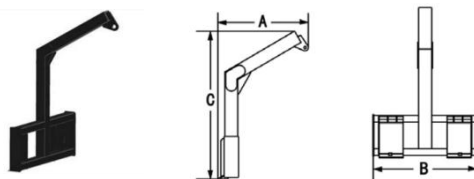

型号 Model	LA-041-1500	LA-041-2500	LA-041-4000
总长 A Overall Length A (mm)	1115	1115	1115
总宽 B Overall Width B (mm)	1274	1274	1274
总高 C Overall Height C (mm)	1809	1809	1809
载重量 Load Capacity (kg)	1500	2500	4000
前伸 Stretching Distance (mm)	1200	1200	1200
自重 Dead Weight (kg)	182	220	267

4.9 圆木抱叉 LOGGING GRABS

	型号 Model	总长 Overall Length (mm)	总宽 Overall Width (mm)	闭合高度 Height at the Shut Position (mm)	张开高度 Height at the Open Position (mm)	张开角度 Open Angle	最大调整间隙 Max. Control Gap (mm)	最小调整间隙 Min. Control Gap (mm)	安装距 Installation Distance (mm)
	LA-046-1200	1298	1206	890	1075	45°	1143	230	380
	LA-046-1600	1298	1587	890	1075	45°	1524	230	380



园林 / 农附具
FORESTRY/
AGRICULTURAL
ATTACHMENTS

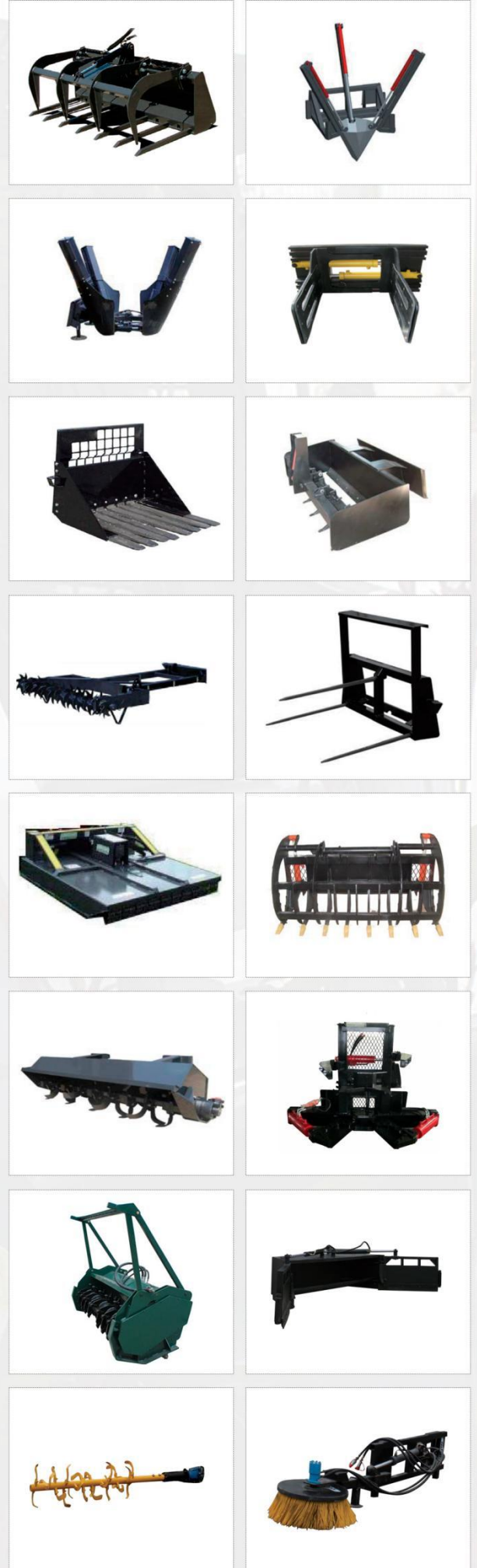

5. 园林/农附具

FORESTRY/AGRICULTURAL ATTACHMENTS

5.1 农用抓斗 AGRICULTURAL GRAPPLE FORKS



型号 Model	LA-051-1500	LA-051-1700	LA-051-1800
总长 Overall Length (mm)	516	516	516
总宽 Overall Width (mm)	1524	1676	1829
总张开高度 Overall Height at the Open Position (mm)	940	940	940
总闭合高度 Overall Height at the Shut Position (mm)	422	422	422

5.2 三瓣式 移树机 THREE PETAL TYPE SPADES

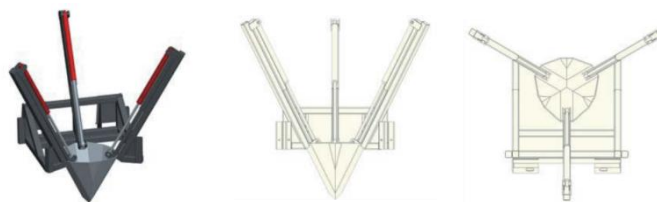

型号 Model	LA-052-1800	LA-052-1900	LA-052-1950	LA-052-2000
总长 A Overall Length A (mm)	1798	1913	1930	1991
总宽 B Overall Width B (mm)	1816	1915	1930	2027
总高 C Overall Height C (mm)	1217	1217	1491	1491
挖掘深度 Digging Depth (mm)	500	574	685	747
底部开放直径 Bottom Opening Diameter (mm)	100	120	140	160
刀瓣角度 Blade Angle	25°	25°	25°	25°
工作流量 Working Flow Range (l/min)	20-65	20-65	20-65	20-65
工作压力 Working Pressure (MPa)	12-21	12-21	12-21	12-21
适合树径 Suitable Tree Diameter (mm)	20-50	40-70	50-80	50-100
净重 Net Weight (kg)	631	682	735	794

5.3 四瓣式(植)移树机 FOUR PETAL TYPE TREE SPADES

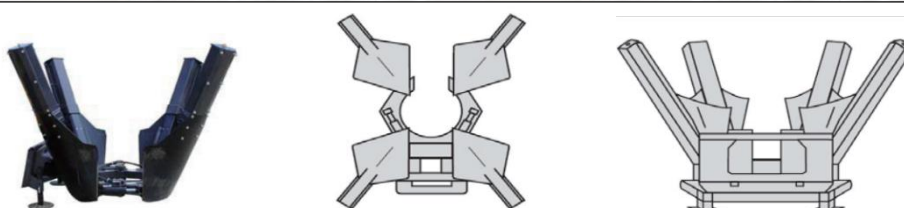

型号 Model	LA-053-2000	LA-053-1700
总长 A Overall Length A (mm)	1661	1974
总宽 B Overall Width B (mm)	2027	1692
总高 C Overall Height C (mm)	1491	1994
挖掘深度 Digging Depth (mm)	747	787
底部开放直径 Bottom Opening Diameter(mm)	160	240
刀瓣角度 Blade Angle	25°	25°
工作流量 Working Flow Range (l/min)	20-65	20-65
工作压力 Working Pressure (MPa)	12-21	12-21
适合树径 Suitable Tree Diameter (mm)	50-10	70-120
净重 Net Weight (kg)	794	1038

5.4 软包夹 SOFT CLAMPS

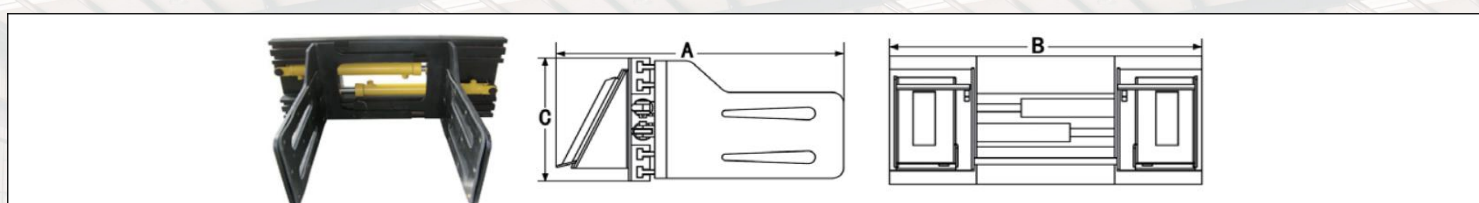

型号 Model	LA-045-950	LA-045-1000	LA-045-1500
载容量 / 载荷中心 Load / Load Center (kg/mm)	1400/500	2100/500	2500/500
总长 A Length A (mm)	1215	1415	1615
总宽 B Width B (mm)	970	1014	1460
总高 C Height C (mm)	582	582	582
张臂范围 Opening Range (mm)	495~1675	675~2075	475~2105
框架宽度 Frame Width (mm)	026	1040	1460
侧移量 Sideshift (mm)	±100	±100	±100
臂高 Arm Height (mm)	440	440	500
臂厚 Arm Thickness (mm)	37	42	47
臂长 Arm Length (mm)	800	1000	1200
自重 Dead Weight (kg)	472	567	653

5.5 铲运器 SCRAPERS



型号 Model	LA-054-1000	LA-054-1200	LA-054-1400	LA-054-1500
总长 Overall Length (mm)	1067	1219	1372	1524
总宽 Overall Width (mm)	1524	1524	1524	1524
总高 Overall Height (mm)	984	984	984	984
叉数 Number of Forks	8	8	8	8

5.6 平地器 GRADERS

型号 Model		LA-055-1700	LA-055-1800	LA-055-2000
总长 A Overall Length A (mm)		1404	1404	1404
总宽 B Overall Width B (mm)		1652	1804	1957
总高 C Overall Height C (mm)		785	785	785
总深 Overall Depth (mm)		838	838	838
工作宽度 Working Width (mm)		1524	1676	1829
容量 (约) Capacity (approximate) (m³)		0.4	0.44	0.48
总重 (约) Overall Weight (approximate) (kg)		373	420	462

5.7 抓耙器 GRAPPLE RAKES

型号 Model		LA-056-1500	LA-056-1800	LA-056-2100	LA-056-2300
总宽 B Overall Width B (mm)		1520	1830	2130	2348
总长 A Overall Length A (mm)		3095	3095	3095	3095
总高 C Overall Height C (mm)		598	598	598	598
重量 Weight (kg)		554	576	598	619

5.8 草捆叉 BALE SPEARS

型号 Model		LA-057-1200	LA-057-1400
总长 Overall Length (mm)		1168	1168
总宽 Overall Width (mm)		1220	1372
总高 Overall Height (mm)		584	584
杆长 Rod Length (mm)		1042	1042

5.9 割草机 LAWN MOVERS



型号 Model	LA-058-1600	LA-058-1900
工作重量 Working Weight (kg)	780	890
总长 Overall Length (mm)	2095	2360
总宽 Overall Width (mm)	1621	1925
总高 Overall Height (mm)	736	738
切割宽度 Cutting Width (mm)	1524	1828
刀片调整量 Blade Adjustment Range (mm)	76	76
最小切割高度 Min. Cutting Height (mm)	50	50
马达流量 Motor Flow Range (gpm)	15-22	15-22
刀片数量 Number of Blades	2	2

5.10 抓草机 GRASS RAKES

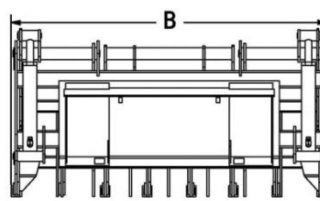
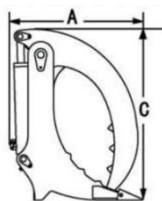

型号 Model	LA-059-1800	LA-059-2000	LA-059-2100
抓斗总宽 Overall Grab Width (mm)	1778	1778	1778
总宽 B Overall Width B (mm)	1830	1980	2134
总高 C Overall Height C (mm)	965	965	965
抓斗张开高度 Grab Opening Height (mm)	1245	1245	1245
总长 A Overall Length A (mm)	686	686	686
重量 Weight (kg)	527	593	652
齿距 Pitch of Teeth (mm)	241	254	216

5.11 旋耕机 ROTARY TILLERS



型号 Model	LA-511-1500	LA-511-1800	LA-511-2100	LA-511-2400
总重 Overall Weight (kg)	290	370	480	630
总宽 Overall Width (mm)	1450	1750	2060	2360
总长 Overall Length (mm)	1820	2120	2322	2620
总高 Overall Height (mm)	600	600	600	600
工作宽度 Working Width (mm)	1220	1524	1828	2130
刀片数量 Number of Blades	28	36	44	52
旋耕深度 Rotary Tillage Depth (mm)	100-150	100-150	100-150	100-150

5.12 树剪 TREE SHEARS



型号 Model	LA-512-800	LA-512-900
总宽 A Overall Length A (mm)	1900	2300
总宽 B Overall Width B (mm)	833	900
总高 C Overall Height C (mm)	1304	1524
工作流量 Working Flow (l/min)	60-120	60-120
工作压力 Working Pressure (MPa)	20	20
最大剪树直径 Max. Tree Cutting Diameter (mm)	300	400
净重 Net Weight (kg)	700	800
树剪刀片材料 Blade Material	NM400	NM400

5.13 拓荒机 FRONTIER ATTACHMENT



型号 Model	LA-513-1200
总宽 Overall Width (mm)	1140
总高 Overall Height (mm)	1456
总长 Overall Length (mm)	2460
拓荒宽度 Frontier Width (mm)	2110
不含压杆的高度 Height without Pressure Rod (mm)	780
不含压杆的长度 Length without Pressure Rod (mm)	2460
工作压力 Working Pressure (MPa)	21
液压流量 Hydraulic Flow (l/min)	110-150
刀头数量 Blade Quantity	46
重量 Weight (kg)	900

5.14 可调式地面清理器 ADJUSTABLE GROUND CLEANERS

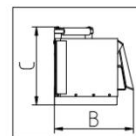
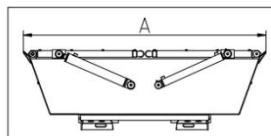

型号	Model	LA-514-1400	LA-514-1300	LA-514-2000
总长 A	Overall Length A (mm)	2210	1790	2600
总宽 B	Overall Width B (mm)	1400	1280	1970
总高 C	Overall Height C (mm)	700	700	700
工作宽度	Working Width (mm)	3200	2600	4000
压力范围	Pressure Range (MPa)	16-22	16-22	16-22
总重	Overall Weight (kg)	352	285	428

5.15 卧床旋转式疏松器 CATTLE BEDDING ROTARY LOOSENER

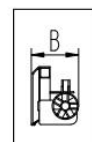
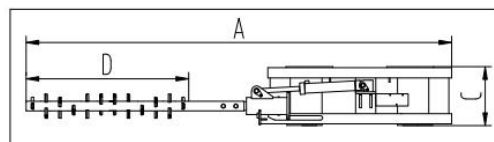

型号	Model	LA-515-400
总长 A	Overall Length A (mm)	3374
总宽 B	Overall Width B (mm)	364
总高 C	Overall Height C (mm)	462
有效工作宽度 D	Effective Working Width D (mm)	1300
最大疏松深度 E	Max. Loosening Depth E (mm)	150
刀片数量	Blade Quantity	24
流量范围	Range of Flow (l/min)	65-120
重量	Weight (kg)	234

5.16 卧床清扫刷 CATTLE BEDDING SWEEPER

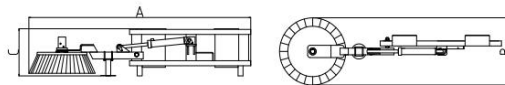

型号	Model	LA-516-800
总长 A	Overall Length A (mm)	2670
总宽 B	Overall Width B (mm)	800
总高 C	Overall Height C (mm)	560
流量范围	Range of Flow (l/min)	45-80
压力范围	Pressure Range (MPa)	16-20
操作重量	Operating Weight (kg)	125

5.17 清扫刷 SWEEPERS

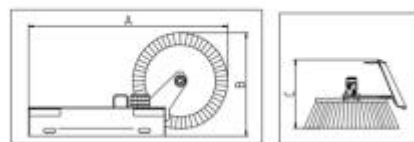

型号	Model	LA-061-1700	LA-061-1200
总长 A	Overall Length A (mm)	1670	1190
总宽 B	Overall Width B (mm)	860	860
总高 C	Overall Height C (mm)	570	570
盘刷直径 D	Brushing Disc Diameter D (mm)	800	800
盘刷可调范围 E	Brushing Disc Adjustable Range E (mm)	80	80
流量范围	Range of Flow (l/min)	50-80	50-80
压力范围	Pressure Range (MPa)	16-20	16-20
操作重量	Operating Weight (kg)	70	55



其他附具 OTHER ATTACHMENTS

6. 其他附具 OTHER ATTACHMENTS

6.1 回料机 FEEDERS

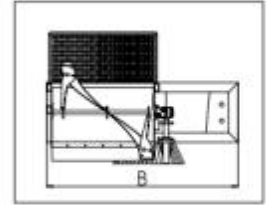
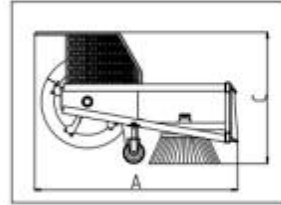

型号 Model	LA-062-1620	LA-062-1620M
总长 A Overall Length A (mm)	1710	1710
总宽 B Overall Width B (mm)	1620	1620
总高 C Overall Height C (mm)	1100	1100
流量范围 Range of Flow (l/min)	45-80	45-80
压力范围 Pressure Range (MPa)	16-20	16-20
操作重量 Operating Weight (kg)	160	160

6.2 抛料机 THROWER

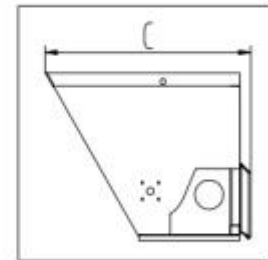
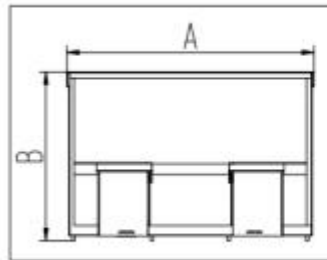

型号 Model	LA-063-1300
总长 A Overall Length A (mm)	1509
总宽 B Overall Width B (mm)	1285
总高 C Overall Height C (mm)	1041
有效斗容 Effective Bucket Capacity (m ³)	0.98
流量范围 Range of Flow (l/min)	70-135
重量 Weight (kg)	410

6.3 回料螺旋转 FEEDER SPIRAL ROTATORS

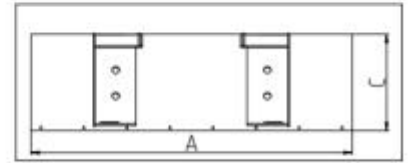
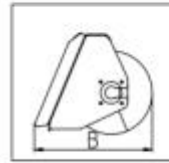

型号	Model	LA-064-0604	LA-064-0604M
总长 A	Overall Length A (mm)	1566	1566
总宽 B	Overall Width B (mm)	575	575
总高 C	Overall Height C (mm)	460	460
压力范围	Pressure Range (MPa)	16-20	16-20
总重	Weight (kg)	140	140

6.4 抱草夹 GRASS CLAMPS



型号	Model	LA-065-060505	LA-065-060510
抱捆直径	Bale Diameter (mm)	500-850	600-1250
额定抱取重量	Rated Lifting Weight (kg)	400	750
操作重量	Operating Weight (kg)	150	180

7. 螺旋钻 AUGERS

7.1 两种形式安架选型 2 TYPES OF MOUNTING OPTIONS

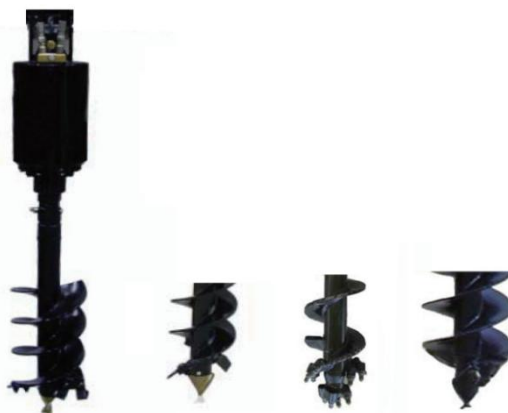

滑移装载机：两种形式安架选型 SKID STEER LOADERS: TWO TYPES OF MOUNTING OPTIONS

安装形式 Installation Type	中置式安装架 Central Mounting Rack	侧移式安装架 Sideshift Mounting Rack
安装架零件号 Mounting Rack Part No	LA-071-9014	LA-071-9033

7.2 螺旋钻机 AUGERS



螺旋钻机型号 Auger Model	LA-2500	LA-3000	LA-3500	LA-4500	
钻孔直径 Drilling Diameter (mm)	100-600	009-001	150-750	150-900	
马达流量要求 Required Motor Flow (l/min)	65	75	75	95	
最大工作压力 Max. Working Pressure (bar)	205	240	240	240	
输出扭矩 Output Torque (Nm)	2452	2900	3643	4535	
输出轴形式 Output Shaft Shape	圆形 65 mm Round 65 mm	P/N21-20200	P/N21-33200	P/N21-33300	P/N21-33500
	2" 六角 2" Hex	P/N21-20200H	P/N21-33200H	P/N21-3330H	P/N21-33500H

7.3 LA-S4 螺旋钻杆系列 LA-S4 SERIES AUGER RODS



65 mm 圆形驱动轴, (长 1.2M) 适用 2500-A682500-4500 螺旋钻机 普通钻(包括钻齿和钻头) 65 mm. Round draft shaft, (length 1.2 m.) suitable for 2500-A682500-4500 augers and regular auger rods (include drill teeth and drill bits)

直径 Diameter	100 mm	150 mm	200 mm	225 mm	250 mm	300 mm	350 mm
零件号 Part No	30-40101200	30-40151200	30-40201200	30-40231200	30-40251200	30-40301200	30-40351200
		400 mm	450 mm	500 mm	600 mm	750 mm	900 mm
		30-40401200	30-40451200	30-40501200	30-40601200	30-40751200	30-40901200

耐磨钻杆(包括硬质合金齿和硬质合金钻头) Wear-resistant auger rods (include carbide teeth and carbide drill bits)

直径 Diameter	100 mm	150 mm	200 mm	225 mm	250 mm	300 mm	350 mm
零件号 Part №	30-40105200	30-40155200	30-40205200	30-40235200	30-40255200	30-40305200	30-40355200
		400 mm	450 mm	500 mm	600 mm	750 mm	900 mm
		30-40405200	30-40455200	30-40505200	30-40605200	30-40755200	30-40905200

极限耐磨钻杆(包括硬质合金齿和极限挖掘钻头) Extreme wear-resistant auger rods (include carbide teeth and extreme excavation bits)

直径 Diameter	100 mm	150 mm	200 mm	225 mm	250 mm	300 mm	350 mm
零件号 Part №	30-40106200	30-40156200	30-40206200	30-40236200	30-40256200	30-40306200	30-40356200
		400 mm	450 mm	500 mm	600 mm	750 mm	900 mm
		30-40406200	30-40456200	30-40506200	30 40606200	30-40756200	30-40906200

高流量螺旋钻机; 动力头型号 High flow augers, powerhead models

螺旋钻机型 Auger Drill Model		LA-072-500	LA-072-600	LA-072-750	LA-072-900
钻孔直径 Drilling Diameter (mm)		150-900	150-900	150-900	150-900
马达流量要求 Required Motor Flow (l/min)		95	115	135	115
工作压力 Working Pressure (bar)		240	240	240	240
输出扭矩 Output Torque (Nm)		5667	7055	7170	7559
输出轴尺寸 Output Shaft Size	方型 75 mm Square 75 mm	P/N21-34300	P/N21-34400	P/N21-35400	P/N21-355000

7.4 LA-S5 系列延伸杆选型 LA-S5 SERIES EXTENSION ROD SELECTION

零件号 Part No	延伸杆长度 Extension Rod Length (mm)	输出轴形式 Output Shaft Type	输出轴尺寸 Output Shaft Size (mm)
31-5100600	1000	方型驱动 Square Drive	75
31-5150600	1500	方型驱动 Square Drive	75
31-5200600	1000	方型驱动 Square Drive	75

LA-S5 螺旋钻杆系列 -75 mm 方形驱动轴, (长 1.5m) 适用 5500-70002k-8000 螺旋钻机 普通钻杆(包括钻齿和钻头) LA-S5 Series auger rods -75 mm. square drive shaft, (length 1.5 m.) suitable for 5500-70002k-8000 auger / regular auger rods (include drill teeth and bits)

直径 Diameter	150 mm	200mm	225 mm	250 mm	300 mm	350 mm
零件号 Part No	30-50151600	30-50201600	30-50231600	30-50251600	30-50301600	30-50351600
直径 Diameter	400 mm	450 mm	500 mm	600 mm	750 mm	900 mm
零件号 Part No	30-50401600	30-50451600	30-50501600	30-50601600	30-50751600	30-50901600

耐磨钻杆(包括硬质合金齿和硬质合金钻头) Wear-resistant auger rods (include carbide teeth and carbide drill bits)

直径 Diameter	150 mm	200 mm	225 mm	250 mm	300 mm	350 mm
零件号 Part No	V/N	30-50205600	30-50235600	30-50255600	30-50305600	30-50355600
直径 Diameter	400 mm	450 mm	500 mm	600 mm	750 mm	900 mm
零件号 Part No	30-50405600	30-50455600	30-50505600	30-50605600	30-40755600	30-50905600

软岩钻杆(包括岩石齿和岩石钻头) Soft rock auger rods (including rock teeth and rock bits)

直径 Diameter	150 mm	200 mm	225 mm	250 mm	300 mm	350 mm
零件号 Part No	30-50156600	30-50206600	30-50236600	30-50256600	30-50306600	30-50356600
直径 Diameter	400 mm	450 mm	500 mm	600 mm	750 mm	900 mm
零件号 Part No	30-50406600	30-50456600	30-50506600	30-50606600	30-50756600	30-50906600

8. 连续开沟器 CONTINUOUS DITCHERS

8.1 LA-073 系列 LA-073 SERIES



LA-073-600

零件号 Part №	描述 Description
41-06000	LA-073-600 挖沟机包括清沟器和 1 / 2" 软管 * 要求的最低流量: 35 lpm@160-240 bar LA-073-600 Trencher includes crumber and 1/2" hose * Minimum flow requirements: 35 lpm@160-240 bar

LA-073-900

零件号 Part №	描述 Description
45-09000	LA-073-900 挖沟机包括清沟器和 1 / 2" 软管 * 要求的最低流量: 45 lpm@180-240 bar LA-073-900 Trencher includes crumber and 1/2" hose * Minimum flow requirements: 45 lpm@180-240 bar

LA-073-600, LA-073-900 安装栓 MOUNTING BOLTS FOR LA-073-600, LA-073-900

零件号 Part №	描述 Description
15-2912	通用滑移装载机-侧移架 / Universal Skid Steer Loader - Sideshift
15-53000	挖掘机 30 mm 销栓 / Excavator 30 mm bolt
15-53500	挖掘机 35 mm 销栓 / Excavator 35 mm bolt
15-54000	挖掘机 40mm 销栓 Excavator 40 mm bolt

推荐的耐磨零件/备件 RECOMMENDED WEAR-RESISTANT PARTS/SPARE PARTS

零件号 Part №	描述 Description
44-2010	钻齿-LH Drill Teeth-LH
44-2011	钻齿-RH Drill Teeth-RH
44-2001	硬质合金齿-LH Carbide Teeth LH
44-2002	硬质合金齿-中心点 Carbide Teeth - Center Point
44-2003	硬质合金齿-RH Carbide Teeth - RH
42-1033	12T 链轮齿 12T Sprocket Teeth
99-1207	前滚轴轴承 Front Roller Bearing
99-1603	前滚轴簧环 Front Roller Circlip
42-1900	前滚轴配套轴承和簧环 Front Roller Bearing and Circlip
44-2025	单链叶片间距 64x32Sm (MT900) Single Stranded Blade Spacing 64x32Sm (MT900)
44-2026	单链叶片间距 48x24Sm (MT600) Single Stranded Blade Spacing 48x24Sm (MT600)
44-2022	连接销 & 锁定销 Connecting Pin & Locking Pin

LA-073 系列链条 LA-073 SERIES CHAINS

链条长度 / 类型 Chain Length/Type	宽度 Width			
	100	150	200	300
600 泥土 Soil 600	44-2901	44-2903	44-2905	-
600 硬质合金混凝土 Carbide Concrete 600	44-2902	44-2904	44-2906	-
600 硬质合金 Carbide 600	44-2918	44-2913	44-2914	-
900 泥土 Soil 900	44-2907	44-2909	44-2911	44-2933
900 硬质合金混凝土 Carbide Concrete 900	44-2908	44-2910	44-2912	44-2934
900 硬质合金 Carbide 900	44-2916	44-2920	44-2921	44-2935

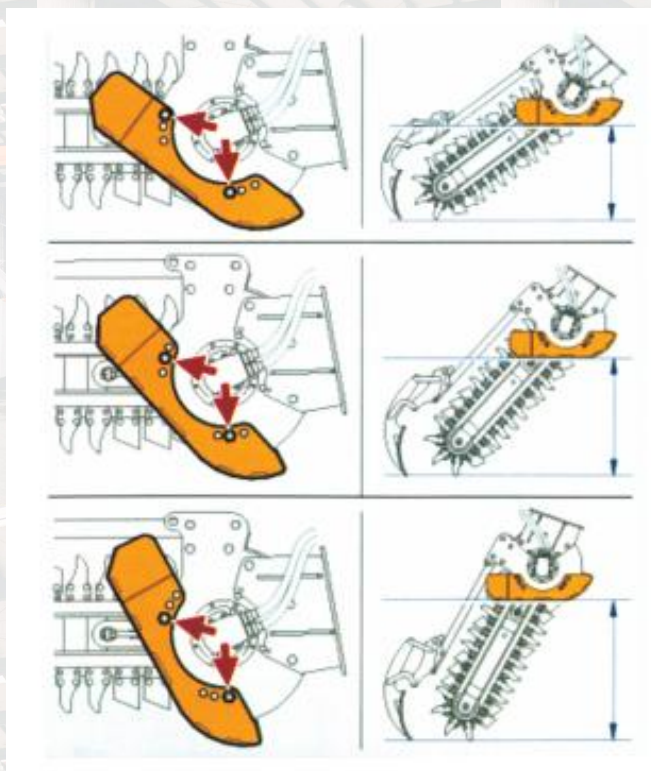

LA-073 系列挖沟机深度设置 LA-073 SERIES TRENCHER DEPTH SETTINGS

LA-073 系列挖沟机 LA-073 SERIES TRENCHER		LA-073 挖沟机 LA-073 Trencher		
600	006	006	1200	1500
300	600	600	800	1000
450	750	750	1000	1250
600	006	006	1200	1500

8.2 LA-074 系列 LA-074 SERIES

LA-0734 系列 LA-0734 SERIES

LA-0734-900, LA-0734-1200, LA-0734-1500

零件号 Part №	描述 Description
43-09100	LA-0734-900 挖沟机包括清沟器和 1 / 2" 软管 * 要求的最低流量: 601pm@180-240 bar LA-0734-900 Trencher includes crumber and 1/2" hose * Minimum flow requirements: 601 pm@180-240 bar
43-12100	LA-0734-1200 挖沟机包括清沟器和 1 / 2" 软管 * 要求的最低流量: 70 lpm@180-240 bar LA-0734-1200 Trencher includes crumber and 1/2" hose * Minimum flow requirements: 70 lpm@180-240 bar
43-15100	LA-0734-1500 挖沟机包括清沟器和 1 / 2" 软管 * 要求的最低流量: 80 lpm@180-240 bar LA-0734-1500 Trencher includes crumber and 1/2" hose * Minimum flow requirements: 80 lpm@180-240 bar

LA-0734 系列安装栓 LA-0734 SERIES MOUNTING BOLTS

零件号 Part №	描述 Description
15-2913	通用滑移装载机-侧移架-重型 Universal Skid Steer Loader - Sideshifter - Heavy Duty Type

挖掘机安装栓 EXCAVATOR MOUNTING BOLTS

销栓大小 Bolt Size	40 mm	45 mm	50 mm	55 mm	60 mm	65 mm
零件号 Part №	15-64000	15-64500	15-65000	15-65500	15-66000	15-66500

推荐的耐磨零件/备件 RECOMMENDED WEAR-RESISTANT PARTS

零件号 Part №	描述 Description
44-3001	钻齿-LH Drill Teeth-LH
44-3002	钻齿-RH Drill Teeth-RH
44-3003	硬质合金齿-LH Carbide Teeth-LH
44-3004	硬质合金齿-中心点 Carbide Teeth - Center Point
44-3005	硬质合金齿-RH Carbide Teeth-RH
43-1019	14T 链轮齿 14T Sprocket Teeth
99-1213	前滚轴轴承 Front Roller Bearing
99-1607	前滚轴簧环 Front Roller Circlip
43-1900	前滚轴配套轴承和簧环 Front Roller Bearing and Circlip
44-3017	单链叶片 58 链节 (0060HX) Single Chain Blade 58 Links (0060HX)
44-3013	单链叶片 72 链节 (1200) Single Chain Blade 72 Links (1200)
44-3015	单链叶片 86 链节 (1500) Single Chain Blade 86 Links (1500)

LA-0734 系列链条 LA-0734 SERIES CHAINS

链条长度 / 类型 Chain Length/Type	宽度 Width (mm)				
	150	200	250	300	350
900 泥土 Soil 900	44-3904	44-3907	44-3910	44-3913	44-3916
900 硬质合金混凝土 Carbide Concrete 900	44-3905	44-3908	44-3911	44-2914	44-3917
900 硬质合金 Carbide 900	44-3906	44-3909	44-3912	44-2915	44-3918
1200 泥土 Soil 1200	44-3922	44-3925	44-3928	44-3931	-
1200 硬质合金混凝土 Carbide Concrete 1200	44-3923	44-3926	44-3929	44-3932	-
1200 硬质合金 Carbide 1200	44-3924	44-3927	44-3930	44-3933	-
1500 泥土 Soil 1500	44-3937	44-3940	-	-	-
1500 硬质合金混凝土 Carbide Concrete 1500	44-3938	44-3941	-	-	-
1500 硬质合金 Carbide 1500	44-3939	44-3942	-	-	-

9. 连滑移装载机配液压工具栏

SKID STEER LOADERS HYDRAULIC TOOLBARS

9.1 动力站-滑移装载机 SKID STEER LOADER POWER STATION



动力站-滑移装载机 SKID STEER LOADER POWER STATION

输出流量 Output Flow	20/140 lpm
输出压力 Output Pressure	140 bar
重量 Weight	2800 kg
长度 Length	3400 mm
宽度 Width	1800 mm
高度 Height	2070 mm
接口 Port	平口快速接头 / Flat Quick-Connector
品牌 Brand	WEITAI

9.2 液压圆盘锯 – LA-25 HYDRAULIC CIRCULAR SAW-LA-25



锯片尺寸 Saw Blade Size	1 in 安装孔, 14 in (350 mm) 直径的砂轮锯片 / 1 Inch Mounting Hole, 14 Inch (350 mm) Diameter Grinding Wheel Saw Blade
压力范围 Pressure Range	104-140 bar
流量范围 Range of Flow	26-34 lpm
转速 Rotating Speed	4500 rpm
重量 Weight	9.1 kg
长×宽 Length x Width	53.3 cm×28cm
连接 Connector	3/8 in 平口快速接头 / 3/8 Inch Flat Quick-Connector
品牌 Brand	WEITAI

9.3 液压金刚石链锯 - LA-11

HYDRAULIC DIAMOND CHAINSAW- LA-11



链板尺寸 Chain Size	46 cm
压力范围 Pressure Range	70-140 bar
流量范围 Range of Flow	26-34 lpm
重量 Weight	11 kg
长度 Length	97 cm
宽度 Width	23 cm
连接 Connector	3/8 in 平口快速接头 / 3/8 Inch Flat Quick-Connector
品牌 Brand	WEITAI

9.4 液压链锯- LA-06 HYDRAULIC CHAINSAW- LA-06



链板长度 Chain Length	300-460 mm
流量范围 Range of Flow	26-34 lpm
压力 Pressure	105-140 bar
重量 Weight	2.8 kg
长度 Length	36 cm
宽度 Width	23 cm
连接 Connector	3/8 inch
品牌 Brand	WEITAI

9.5 液压手持镐 - LA-15 HYDRAULIC HAND PICK- LA-15



流量范围 Range of Flow	26-34 lpm
镐钎尺寸 Pick & Drill Size	580 in 六方椭圆领钢镐钎 / 580 Inch Hexagonal Oval Collar Steel Pick & Drill
重量 Weight	7.25 kg
长度 Length	43 cm
宽度 Width	8 cm
连接 Connector	3/8 in 平口快速接头 / 3/8 Inch Flat Quick-Connector
品牌 Brand	WEITAI

9.6 液压轻型破碎镐 - LA-45

HYDRAULIC LIGHT BREAKING PICK- LA-45



压力范围 Pressure Range	105-140 bar
流量范围 Range of Flow	26-34 lpm
重量 Weight	22 kg
长度 Length	65 cm
宽度 Width	36 cm
连接 Connector	1-1/4×6 in. 六方 / 1-1/4×6 Inch Hexagon
品牌 Brand	WEITAI

9.7 破碎镐 - LA-67 BROKEN PICKAXE-LA-67



流量范围 Range of Flow	26-34 lpm
镐钎尺寸 Pick & Drill Size	1-1/8×6 in.or 1-1/4×6 in
压力 Pressure	105-140 bar (10.5-14 MPa)
重量 Weight	30-34 kg
长度 Length	68-73 cm
宽度 Width	41-46 cm
连接 Connector	3/8 in 平口快速接头 / 3/8 Inch Flat Quick-Connector
品牌 Brand	WEITAI

9.8 液压锤钻 - LA-08 HYDRAULIC HAMMER DRILL - LA-08



装卡尺寸 Card Size	SDS 加强钻头-钻混凝土钻头可达 22CM / SDS Reinforced Drill - Concrete Drill Bit Up To 22 Cm.
流量范围 Range of Flow	11-34 lpm
重量 Weight	2.7 kg
长度 Length	35 cm
宽度 Width	14 cm
品牌 Brand	WEITAI

9.9 液压锤钻 - LA-45 HYDRAULIC HAMMER DRILL - LA-45



装卡尺寸 Card Size	#736 skil 六方卡头 / #736 skil Hexagon Card
流量范围 Range of Flow	26-34 lpm
重量 Weight	20 kg
长度 Length	57 cm
宽度 Width	35 cm
连接 Connector	3/8 in 平口快速接头 / 3/8 Inch Flat Quick-Connector
品牌 Brand	WEITAI

9.10 液液压潜孔钻 - LA-58 HYDRAULIC DTH DRILL - LA-58



装卡尺寸 Card Size	lin×4-1/4in 六方 / Lin×4-1/4 In Hexagon
流量范围 Range of Flow	26-34 lpm
重量 Weight	30 kg
长度 Length	66 cm
宽度 Width	46 cm
连接 Connector	3/8 in 平口快速接头 / 3/8 Inch Flat Quick-Connector
品牌 Brand	WEITAI

9.11 液液压岩心钻 - LA-12 HYDRAULIC CORE DRILL - LA-12



钻头尺寸 Drill Size	1.6-35.6 cm 直径的岩心钻 1.6-35.6 cm. Diameter Core Drill
流量范围 Range of Flow	26-34 lpm
重量 Weight	8.6 kg
长度 Length	48 cm
宽度 Width	10 cm
连接 Connector	3/8 in 平口快速接头 / 3/8 Inch Flat Quick-Connector
品牌 Brand	WEITAI

9.12 液压污水泵 - LA-20 HYDRAULIC SEWAGE PUMP - LA-20



能力 Power	946 lpm
流量范围 Range of Flow	15-34 lpm
重量 Weight	6.3 kg
长度 Length	19 cm
宽度 Width	24 cm
连接 Connector	3/8 in 平口快速接头 / 3/8 Inch Flat Quick-Connector
品牌 Brand	WEITAI

9.13 液压渣浆泵 - LA-03 HYDRAULIC SLURRY PUMP - LA-03



能力 Power	1688 lpm
流量范围 Range of Flow	26-34 lpm
重量 Weight	14.52 kg
长度 Length	35.5 cm
宽度 Width	30.4 cm
连接 Connector	3/8 in 平口快速接头 / 3/8 Inch Flat Quick-Connector
品牌 Brand	WEITAI

9.14 液压渣浆泵 - LA-08 HYDRAULIC SLURRY PUMP - LA-08



能力 Power	3028 lpm
流量范围 Range of Flow	26-34 lpm
重量 Weight	26.7 kg
长度 Length	48.3 cm
宽度 Width	38 cm
连接 Connector	3/8 in 平口快速接头 / 3/8 Inch Flat Quick-Connector
品牌 Brand	WEITAI

青岛威泰智能装备有限公司

Qingdao Weitai Intelligent Equipment Co., Ltd.

www.weitai-group.com

www.steerloaders.com